



vma

SMART TECHNOLOGY
FOR GOOD

Company presentation

Smart warehouses,
Automation
and more...





vma

SMART TECHNOLOGY
FOR GOOD

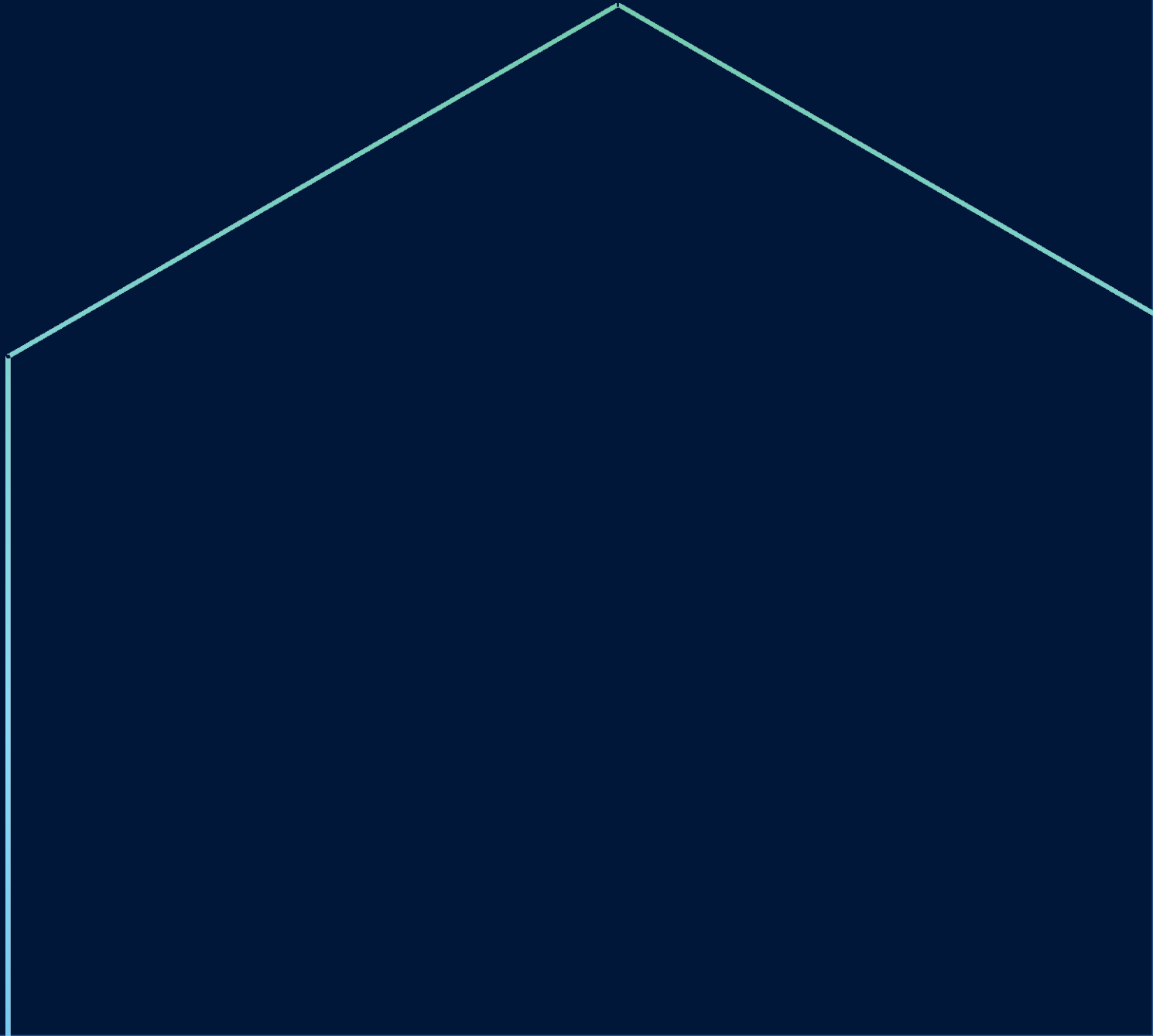

Values



Our mission

vma, through its people, is a strong multi-technical partner, offering sustainable technological and innovative total solutions in successful long-term collaborations.



vma

SMART TECHNOLOGY
FOR GOOD



Space Industry

Pharmacy Technologies

Automation Segment

Building Engineering

- 1050 employees
- 225 M€ turnover
- 10 M€ Ebit
- Active in Belgium, Luxembourg, Poland, US, UK, Germany, Sweden, Slovakia, ...

vma locations:

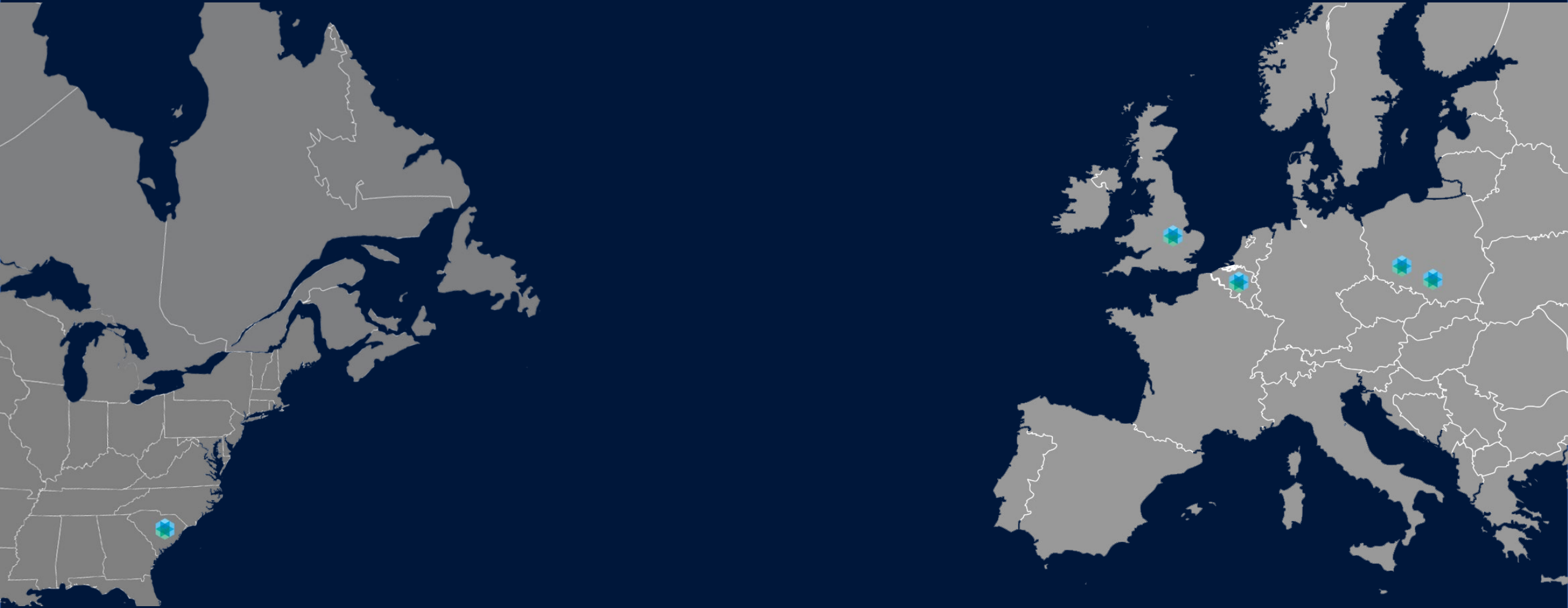



Our differentiators

Our differentiators:

- We are project driven, flexible, reactive organisation
- We care about long term relations based on partnership
- We have specific knowledge and experience
- We deliver total solutions
- We own workshop for MV and panels

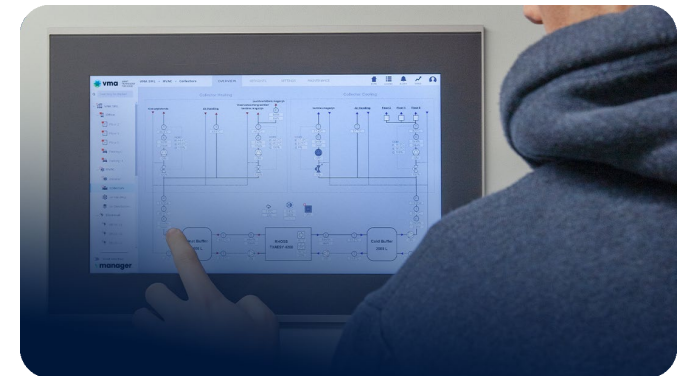
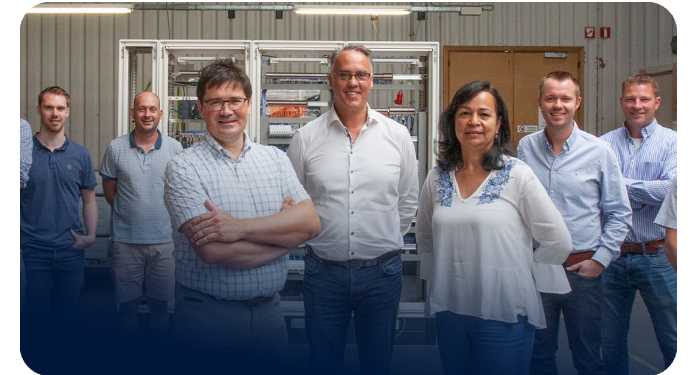

Our differentiators

- Regional/local + international presence (close to client)
- Certifications:
VCA**, ISO9001, Class 8 (Highest Level Government), UL
- Financially strong organisation





Smart warehouses*

*Few examples



vma

SMART
TECHNOLOGY
FOR GOOD

Warehousing

Location

Horten, Norway

Project

ESCALA MOVU

Year

2025 (Finished)

Client

MOVU for Kongsberg

Specific technologies

Smart Autonomous Warehousing,
Automatic Infeed/Outfeed,
Dynamic & Static Shuttle Charging,
WiFi Communications, Stacking

Movu – Kongsberg, Escala System

Autonomous warehousing system. Battery powered robots picking up boxes and storing them on the racking, then moving away for another task. System 15m wide, 45m deep, 4 story high.

Within this project we have realized the following scopes:

- HW Design, Electrical Installation, mechanical installation.

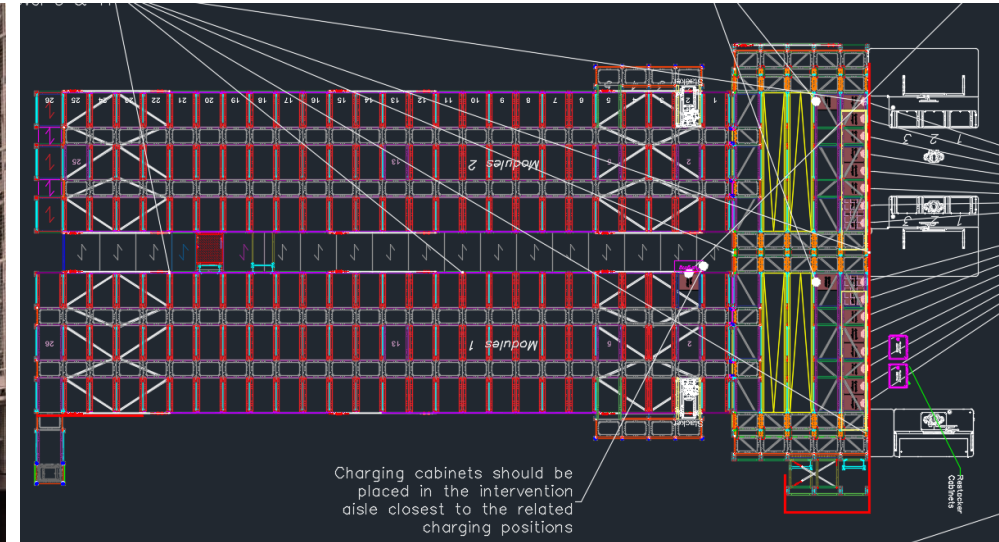
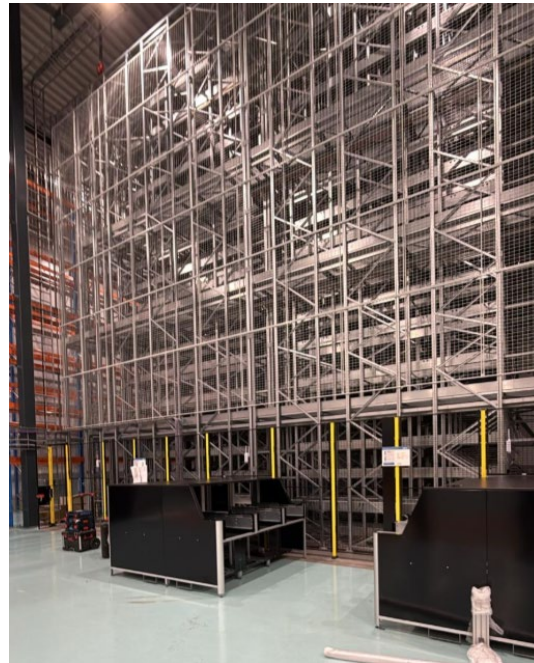



vma

SMART
TECHNOLOGY
FOR GOOD

Warehousing

Location

Crailsheim, Germany

Project

ATLAS MOVU

Year

2025 (Finished)

Client

MOVU for P&G

Specific technologies

Smart Autonomous Warehousing,
Automatic Infeed/Outfeed,
Dynamic & Static Shuttle Charging,
WiFi Communications

Movu – Procter & Gamble, Atlas System

Autonomous warehousing system. Battery powered shuttles picking up EUR pallets, 140cm tall. storing them on the racking, then moving away for next task. System 100m wide, 45m deep, 4 story high.

Within this project we have realized the following scopes:

- HW Design, Cabinet Building, Electrical Installation, mechanical installation.

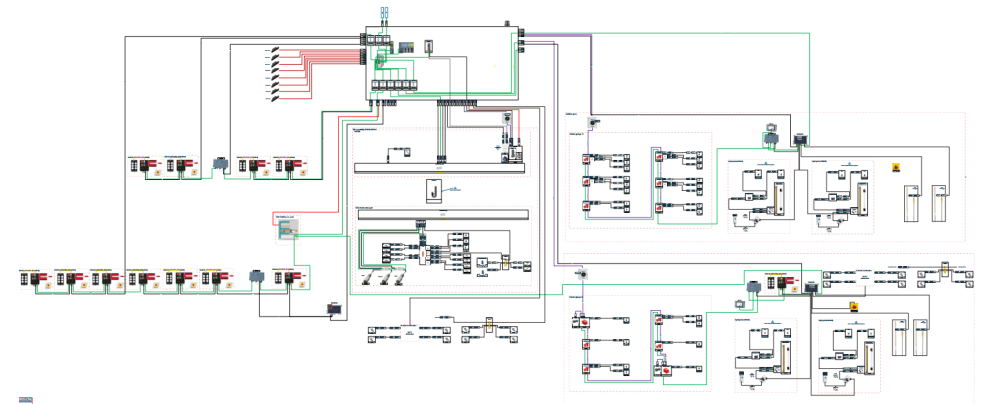
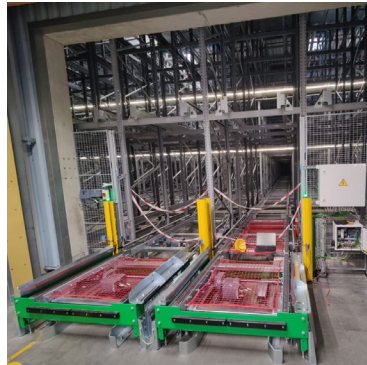



Automation segment

Automation Segment

We have been active in the automation segment for over 30 years.

Range of our work include:

- Total projects scope
- Eplan, network and software design
- Electrical installations* and software deployment onsite
- Offline programming & digital twin realization

- Panel building (workshop in Poland)
- Tagging/Track & Trace
- MES
- Training & production back up

Our capacity:

- Robot offline: 35 programmers
- Robot online: 60 programmers
- PLC: 40 programmers
- Eplan design: 16 engineers

*all services (except electrical installation) can be ordered separately on a **fixed price** basis or **hourly rate**.

Automation Segment

Robotics scope overview:

- Robot station concept development
- Robot path preparation
- Process guns selection, proces study
- Material handling and fitting
- Cycle time optimization
- Reachability study
- Off site / On site Robot programming
- Robot on site commissioning
- Technological processes quality optimisation
- On site programs testing
- OLP documentation
- Construction Checking
- Standardisation (End client standard)
- Safety implementation
- Training
- Operation technical support
- Layout, fundament plan creation



Automation Segment

PLC scope review:

- Network design & implementation
- PLC programming: Offline
- One line PLC programming
- Virtual commissioning
- On-site commissioning
- Visualisations (HMI)
- Standardisation (End client standard)
- Safety analysis
- Technical support
- Documentation



BECKHOFF

New Automation Technology

B&R

A member of the ABB Group

SIEMENS

**PHOENIX
CONTACT**



Allen-Bradley

Automation Segment

Digital Twin scope overview:

- PLC, ROB, Sim software integration
- Production case scenarios testing
- Control concept validation
- Verification of the assumptions of the security concept
- Behaviour models creation
- Drives control
- Kinematic replication
- Virtual Reality implementation (VR)
- Ergonomic study of the station
- Rob tech packiets, plc library debugging
- The possibility of presenting the production to the customer before building the production line





Automation references*

*Few examples after 2020

Automation references





vma

SMART
TECHNOLOGY
FOR GOOD

Location

Košice, Slovakia

Project

Front End Structure

Year

2025-2027 (ongoing)

Client

Mino for VOLVO

Specific technologies

Spot Welding, Gluing, Handling, Stamping,
Self Piercing Rivet, Stud Welding, Nut Welding,
Murr VARIO X System

VOLVO Košice – V326, E-SUV

Within this project we have realized the following scopes:

- Robot and PLC onsite commissioning + programming
- 11 Siemens PLCs
- ROBOTICS: 160 FANUC Robots
- Software: TIA Portal, FANUC ROBOGUIDE,





vma

SMART
TECHNOLOGY
FOR GOOD

Location

Ghent, Belgium

Project

Bodysides, Mainline, Respot, HOP (Manual stations)

Year

2024 – 2025 (Finished)

Specific technologies

Spot Welding, Gluing, Handling, Stamping, ARPLAS, Flow Drill, Arc Welding, Laser Brazing (Permanova), Laser Cutting

VOLVO V216, EX30, Belgium

Within this project we have realized the following scopes:

- Robot and PLC onsite commissioning + programming
- 24 Siemens PLCs
- ROBOTICS: 206 ABB Robots (new OmniCore controller)
- Software: TIA Portal, ABB Robot Studio,





vma

SMART
TECHNOLOGY
FOR GOOD

Location

Regensburg, Germany

Project

UB

Budget

EUR 2.5 milion

Year

2025-2027

Client

OLCI for BMW

Specific technologies

Spot Welding, Gluing, Handling, Stud welding,
Tool changing

BMW Regensburg – BMW NB5

Within this project we have realized the following scopes:

- HW Design, Mechanical Design, Simulation, Offline Robot & PLC programming, Virtual Commissioning, Robot & PLC online commissioning
- PLC: 23 Siemens PLCs
- ROBOTICS: 264 FANUC Robots
- Standard: PLC GSC, ROB V8.2
- Software: EPLAN, Process Simulate, LineSimulator, RoboGuide, TIA Portal

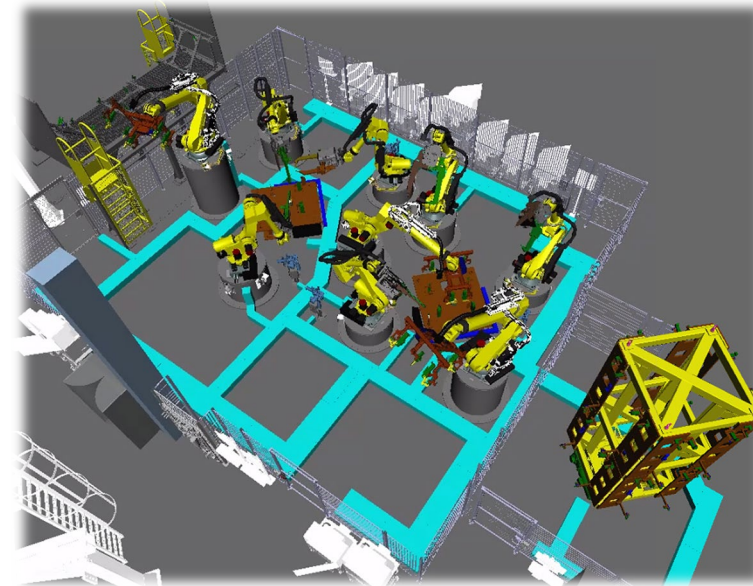



vma

SMART
TECHNOLOGY
FOR GOOD

Location

Mladá Boleslav, Czech Republic

Project

BSO

Year

2025

Client

Bentchor for Skoda

Specific technologies

Spot Welding, Gluing, Handling, Stud welding,
Tool changing

Mladá Boleslav – Skoda SK316/7

Within this project we have realized the following scopes:

- Robot and PLC onsite commissioning
- PLC: 8 Siemens PLCs
- ROBOTICS: 39 FANUC Robots





vma

SMART
TECHNOLOGY
FOR GOOD

Location

Dingolfing, Germany

Project

Front structure

Year

Jan - Sep 2025

Client

FFT for BMW

Specific technologies

Spot Welding, Gluing, Handling, Stud welding,
Tool changing

BMW G50, Dingolfing

Within this project we have realized the following scopes:

- Virtual commissioning,
- PLC offline, online programming, onsite commissioning
- Robot onsite commissioning & programming
- PLC: 12 Siemens PLCs
- ROBOTICS: 140 KUKA Robots

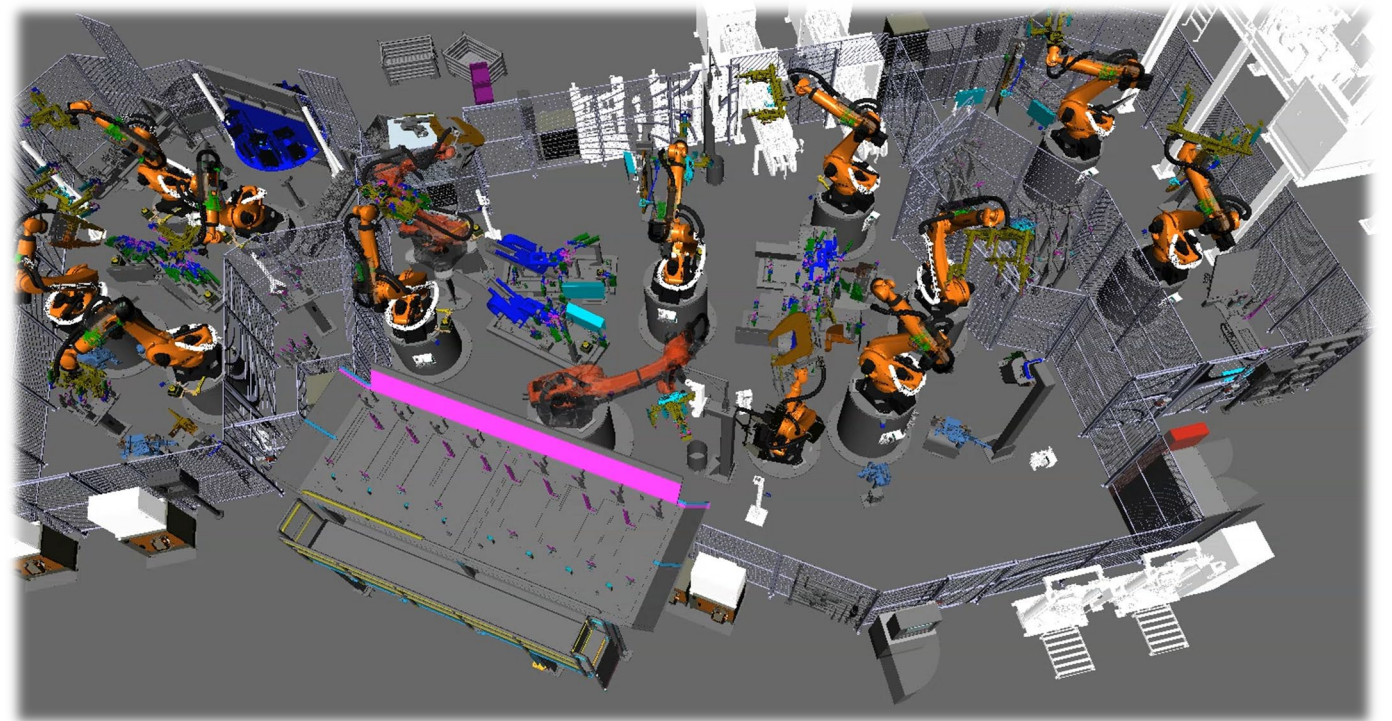



vma

SMART
TECHNOLOGY
FOR GOOD

Location

Germany

Project

Battery cover

Year

Apr 2023 – Jul 2023

Specific technologies

Spot Welding, Gluing, Handling, Stud welding,
Brushing

Laepple, Germany

Within this project we have realized the following scopes:

- Robot offline + online programming
- PLC: 5 Siemens PLCs
- ROBOTICS: 38 KUKA Robots





vma

SMART
TECHNOLOGY
FOR GOOD

Location

Pelhřimov, Czech Republic

Project

Front loader for agricultural machinery

Year

2023

Specific technologies

Arc welding

Agrostroj, Pelhřimov

Within this project we have realized the following scopes:

- Robot onsite commissioning + programming
- ROBOTICS: 20 FANUC Robots





vma

SMART
TECHNOLOGY
FOR GOOD

Battery Assembly Line

Location

Ghent, Belgium

Project

Quality control station

Year

2025

Client

BAR

Specific technologies

ABB Robot, AGV transport, KEYENCE measuring system, 3D printing

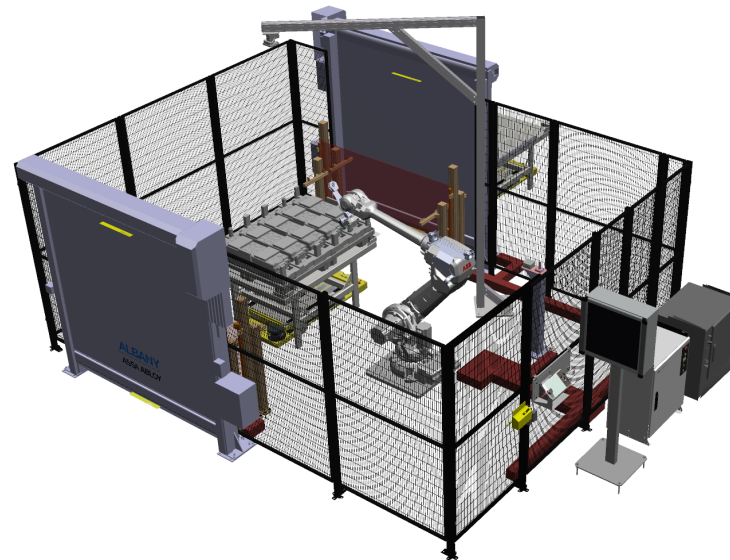

VOLVO Ghent – BOL

The scope of the project included building a complete robotic cell, including the design of tooling. Some components were produced via 3D-printing techniques. It also covered the integration of a Keyence vision system for verifying the removal of plastic covers and for positioning the four types of modules. Another key element was programming the robot with logic for compensating the AGV-table-pallet-module positioning and executing the measurement cycle with result analysis using the Chroma device. The process concluded with automatic pallet classification and sending the AGV to the NOK station if any of the modules failed the inspection.





vma

SMART
TECHNOLOGY
FOR GOOD

Battery Assembly Line

Location

Ghent, Belgium

Project

Vaccum Station

Year

2025

Client

Volvo

Specific technologies

ABB Cobot, AGV transport, Karcher Vaccum system, 3D printing

VOLVO Ghent – Vaccum Station

The scope of the project included building a complete robotic workstation, including the mechanical design of the workstation. Some of the equipment, for example the nozzle brackets were produced with using a 3D printing technology.. It also covered the integration of a Karcher Vaccum system for cleaning of battery tray to remove all types of contaminants that may occur during transportation and previous production processes. Another key element was programming the cobot with logic for PLC and a specification of safety areas that allow for direct operation within human-occupied environments. The entire project was based on a detailed risk analysis and was ultimately verified through strain-gauge measurements.

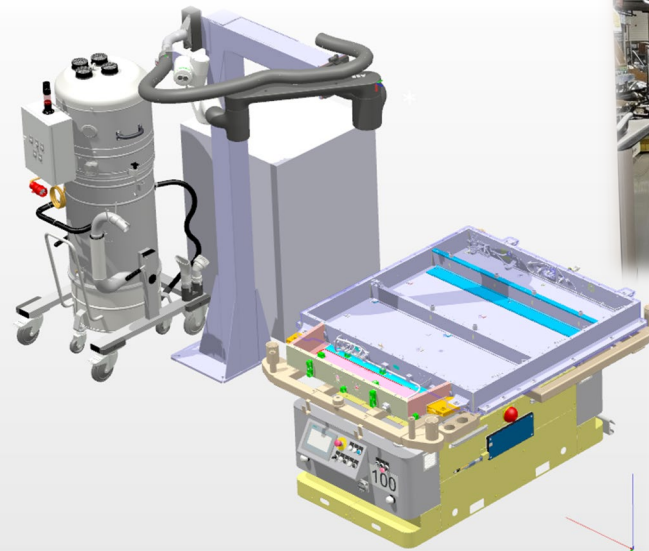



vma

SMART
TECHNOLOGY
FOR GOOD

Logistics

Location

Stuttgart, Germany

Project

KLT

Year

2024 - present

Client

INOS

Specific technologies

ABB Robot, Vision system

Porsche Stuttgart – Logistics KLT

The scope of the project included the integration of an ABB robot with a vision system provided by the client. The entire system enables fully automated palletizing and depalletizing KLT boxes. We began with the initial commissioning of the robot, including the configuration of communication between the PLC controller, the vision system, and the specialized gripper. Subsequently, during the commissioning phase, we collaborated closely with the client to optimize the software until the expected results were achieved. As a robotics partner of Inos, we continue to implement this solution worldwide.

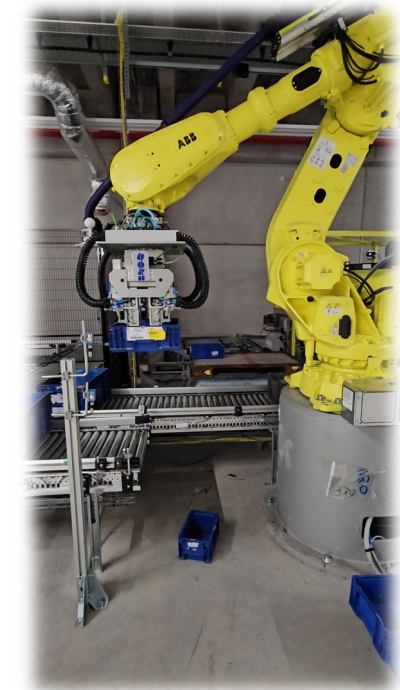



SMART
TECHNOLOGY
FOR GOOD

Logistics

Location

INOS site, Germany

Project

KLT

Year

2025

Client

INOS

Specific technologies

Fanuc Robot, Vision system,
AGV transport,
CAD software and FEM strength
calculations

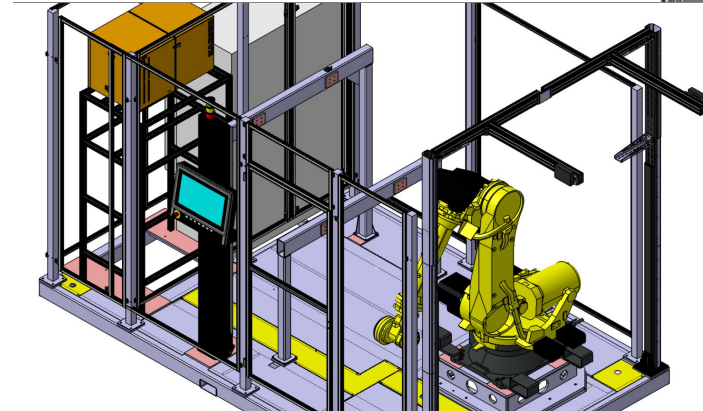
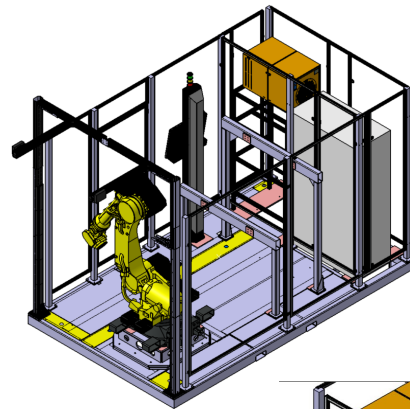

KLT Platform

The scope of the project was a complete mechanical design, manufacturing and commissioning the special KLT platform which was created as a training or show cell. a Fanuc robot with a vision system provided by the client. Once of the hardest requirements was to provide a transportation of the whole platform by the forklift with mounted whole equipment, such as: Fanuc robot, robot' console, PLC & power cabinet, robot controller, fencing and air compressor. This equipment weights around 2700kg with the platform itself weight around 1000kg. The platform also has to have an ability to stand on the 4 feet mounted at the corners. The entire vision and robotics system enables fully automated palletizing and depalletizing KLT boxes. We began with the initial commissioning of the robot, including the configuration of communication between the PLC controller, the vision system and the specialized grippers with toolchanger. In our scope was also to organize a transport the completely mounted platform to client's facility at Germany





vma

SMART
TECHNOLOGY
FOR GOOD

Logistics

Location

Düsseldorf, Germany

Project

KLT

Year

2025

Client

INOS

Specific technologies

Fanuc Robot, Vision system, AGV transport

Porsche Düsseldorf – Platform

The scope of the project included the integration of a Fanuc robot with a vision system provided by the client. The entire system enables fully automated palletizing and depalletizing KLT boxes. We began with the initial commissioning of the robot, including the configuration of communication between the PLC controller, the vision system, and the specialized grippers with toolchanger. We were also involved in the design and fabrication of the tooling for the client. Subsequently, during the commissioning phase, we collaborated closely with the client to optimize the software until the expected results were achieved. As a robotics partner of Inos, we continue to implement this solution worldwide.





vma

SMART
TECHNOLOGY
FOR GOOD

Location

Wolfsburg, Germany

Project

UB, RHI, USA

Year

2023-2025 (Finished)

Client

AUTOROBOT for VW

Specific technologies

Spot Welding, Gluing, Handling, Nut welding, Stamping, Bolt Welding

VW Wolfsburg – VW310, ID.3

Within this project we have realized the following scopes:

- HW Design, Mechanical Design, Simulation, Offline Robot & PLC programming, Virtual Commissioning, Main power supply, Electrical installation, Robot & PLC online commissioning
- PLC: 25 Siemens PLCs
- ROBOTICS: 162 FANUC Robots
- Standard: VASS 6
- Software: EPLAN, Process Simulate, WinMOD, RoboGuide, TIA Portal, ProDiag

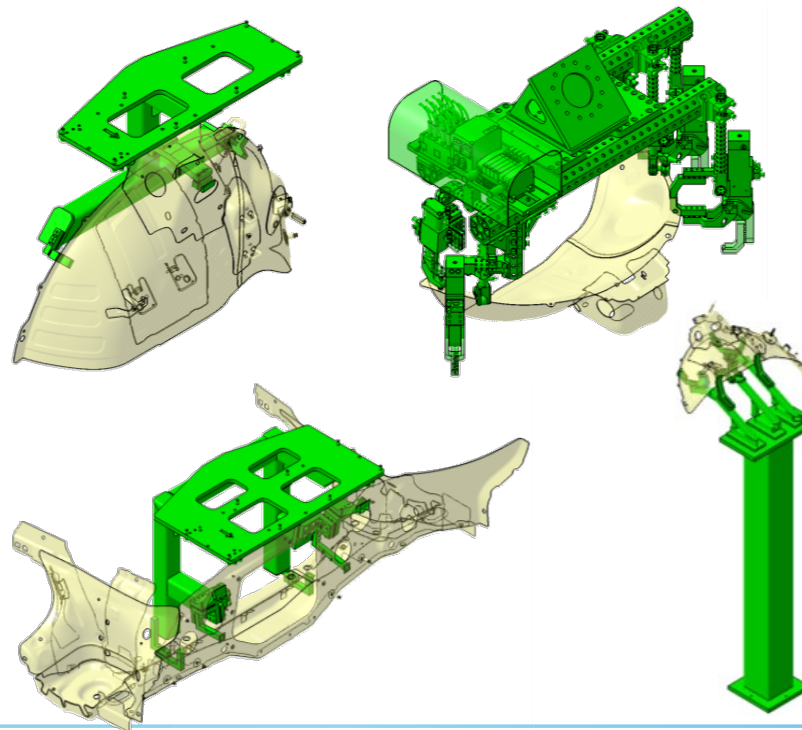



vma

SMART
TECHNOLOGY
FOR GOOD

Location

Emden, Germany

Project

UB

Year

2021-2023

Specific technologies

Spot Welding, Gluing, Handling, Nut welding, Stamping, Bolt Welding, MIG welding, Riveting,

VW Emden Underbody:

In Emden we did series of project on green and brown fields areas. Within individual project we have realized the following scopes:

Apr 2021 VW316 :

- Offline robot programming,
- Online robot commissioning and programming
- PLC: 25 Siemens PLCs
- ROBOTICS: 202 FANUC Robots

Q4 2021-2022 VW316+VW413 :

- Integration new model (VW413) on VW316 lines in the same scope.

Q4 2022 – Nov 2023 VW316+VW413+VW412 :

- Further integration of new model in the same areas and in the same scope.

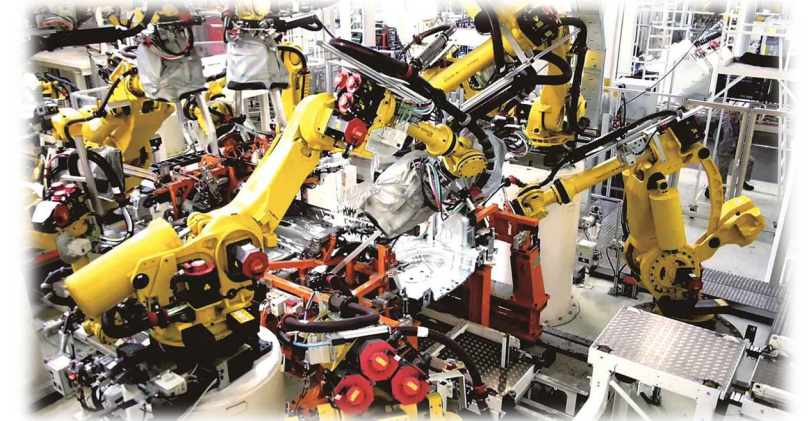



vma

SMART
TECHNOLOGY
FOR GOOD

Location

Emden, Germany

Project

Tailgate

Year

May 2022 – Mar 2023

Specific technologies

Spot Welding, Gluing, Handling, Nut welding, Hemming

VW Emden tailgate:

Another example of realization for VW Emden:

May 2022 – Mar 2023

Realization of a project of tailgate line, where in scope was:

- Online robot commissioning and programming
- ROBOTICS: 39 KUKA Robots

Nov 2022 – May 2023

Integration new model (VW412) on FANUC Robots, on brown field area, where we were working on VW413 lines.

- Online robot commissioning and programming
- ROBOTICS: 36 Fanuc Robots





vma

SMART
TECHNOLOGY
FOR GOOD

Battery Assembly Line

Location

Sweden

Project

Complete battery assembly line

Year

2022 - 2025

Client

EBZ for SCANIA

Specific technologies

Combined technologies specific to battery assembling

EBZ – Scania Sweden

- Battery cells handling, insertion, positioning and alignment, adhesive application, pressing and flanging, laser welding, modules stacking, plasma cleaning, busbar assembly, fitting and welding, default detection and handling, testing.

Receipts for the Integration of 4 different assembly variants.

Works in tight schedule and advanced technologies.

- 24 Siemens 1517F PLCs, 400 drives, 100 switches ± 5.000 signals.
38 ABB Robots, 24 conveying and gantry systems, 28 400 V Panels.
- Soft: PCS7 TIA, Robot Studio, WinMod OLP, simulation & virtual commissioning, IO Link communication protocol, Simatic ProDiag





vma

SMART
TECHNOLOGY
FOR GOOD

Battery Housing Assembly Line

Location

England

Project

Battery housing assembly line

Year

2022 – 2024

Client

Confidential

Specific technologies

Bosch Rexroth – Nexo and SB356 tightening technology, Dürr – EcoHVMP fluid handling technology, Zeltwanger – ZED leak testing technology, KUKA Assembly and Test – P-03404 electrical testing technology, Nissan Motor Manufacturing UK – MKS AGV technology

Automotive

- Battery pack assembly line including: pack components transportation and handling, software guided manual assembling and tightening of components, robot guided automatic thermal paste application and tightening of battery modules, leak testing of battery pack case and cooling circuit, electrical testing of battery modules and assembled battery pack.
- Integration of 2 different variants.
- Works in tight schedule and advanced technologies.
- Hardware: 6 Siemens SIMATIC S7-1500 PLCs, 26 drives, 15 switches, 1 Fanuc robot, 3 conveying systems, 35 AGV's.
- Software: Siemens TIA Portal V16, miKUKA software package, Bosch Rexroth OGS – Operator Guidance System, OPC UA communication protocol





vma

SMART
TECHNOLOGY
FOR GOOD

Battery Assembly Line

Location

Poland

Project

Opel Battery assembling line

Year

2022 - 2024

Client

OLCI Engineering

Opel Stellantis Poland

- Body In White battery assembly line, PLC & OLP Robot programming including commissioning.
- 28 Fanuc Robots
- 3 Allen Bradley PLCs.





vma

SMART
TECHNOLOGY
FOR GOOD

Battery Assembly Line

Location

Germany

Project

Battery assembling line VW

Year

2021

Client

InPro Electric

VW Braunschweig

- Support for fine tuning and commissioning of the complete battery cells assembly line.
- Optimization of assembly line.

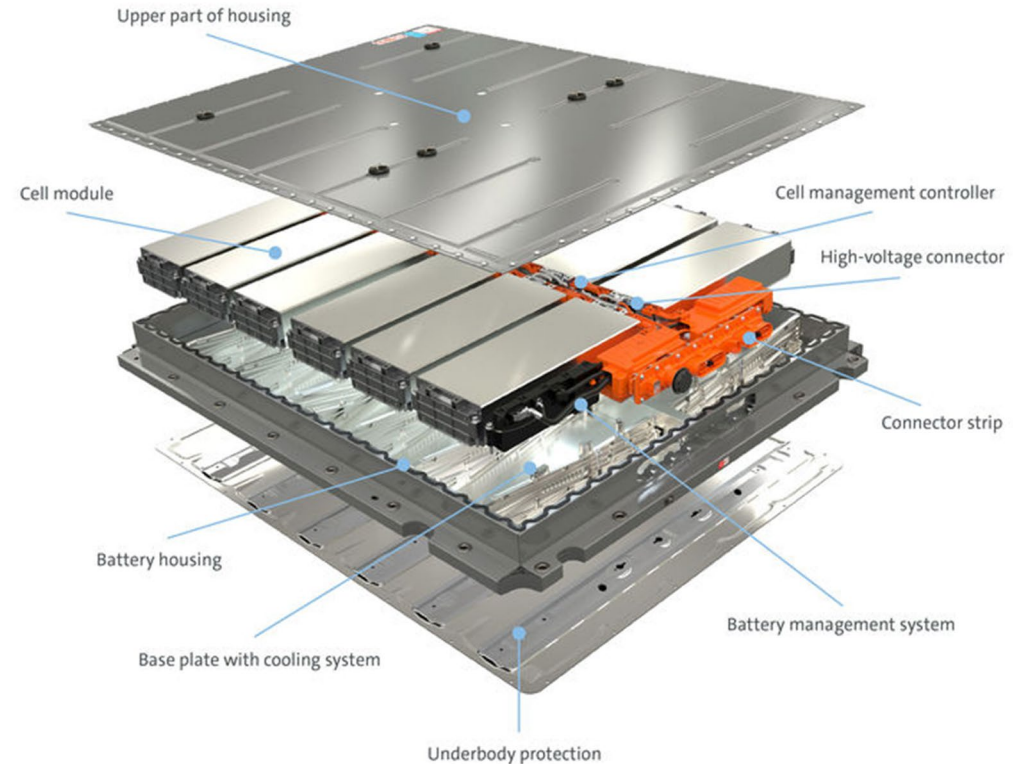



vma

SMART
TECHNOLOGY
FOR GOOD

Location

Audi Vorst (Brussels, Belgium)

Project

AKL stackercrane Audi Brussels

Year

2023-2024

Client

AUDI

Specific technologies

Eplan Pro Panel due to very limited space in cabinets / SEW Movi C / Miconrol/Dunkermotor / interaction with Legato (Audi MES system), interaction with LVS (warehouse control system) / conveyors / crane with balancing : Bellys sway & anti-pendel / Powercap to re-use braking energy

AKL stackercrane Audi Brussels

6 stacker cranes, 1 conveyor, 7 Siemens PLC's, 20 barcode camera's (with automatic length detection and both horizontal/vertical readability) / transport up to 26 different sized KLT boxes / multi crane access to same storage location / 6 Mobile control panels / Data shifting / Traceability
72 motors roller conveyor, double roller band on crane, width adjustment due adjust to size boxes, 6 flaps to push-pull boxes

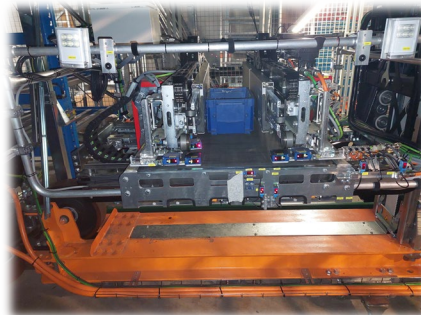



vma

SMART
TECHNOLOGY
FOR GOOD

Location

Audi Vorst (Brussels, Belgium)

Project

AKL stackercrane Audi Brussels

Year

2023-2024

Client

AUDI

Specific technologies

Eplan Pro Panel due to very limited space in cabinets / SEW Movit C / Miconrol/Dunkermotor / interaction with Legato (Audi MES system), interaction with LVS (warehouse control system) / conveyors / crane with balancing : Bellys sway & anti-pendel / Powercap to re-use braking energy

AKL stackercrane Audi Brussels

6 stacker cranes, 1 conveyor, 7 Siemens PLC's, 20 barcode camera's (with automatic length detection and both horizontal/vertical readability) / transport up to 26 different sized KLT boxes / multi crane access to same storage location / 6 Mobile control panels / Data shifting / Traceability
72 motors roller conveyor, double roller band on crane, width adjustment due adjust to size boxes, 6 flaps to push-pull boxes

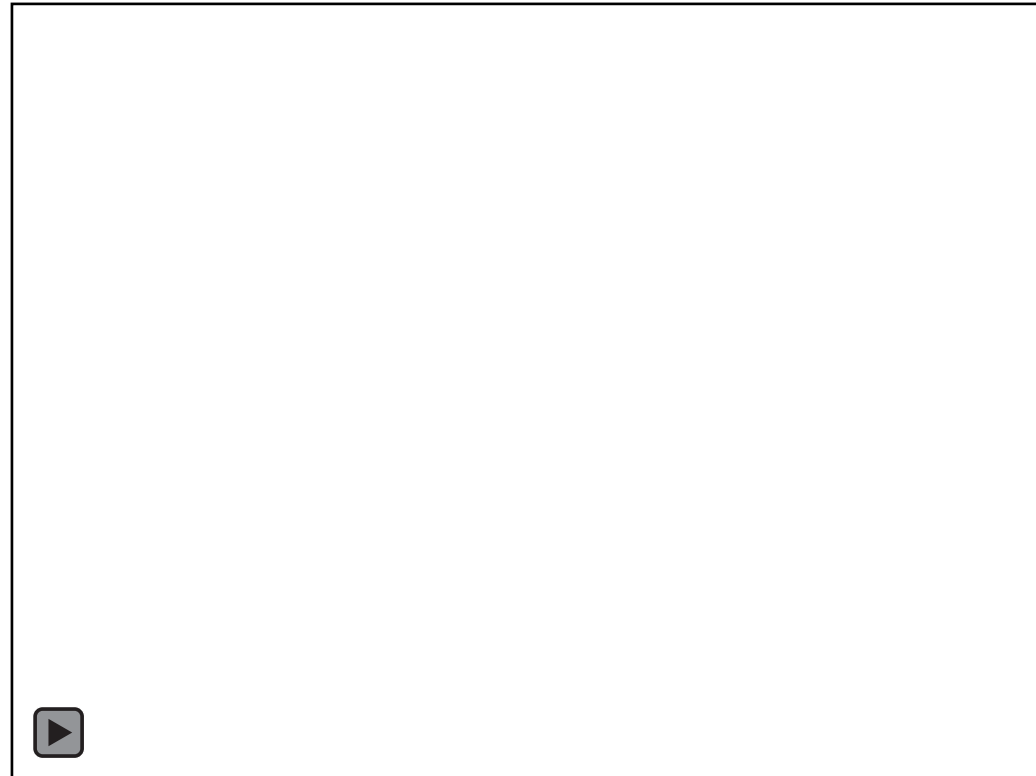



vma

SMART TECHNOLOGY
FOR GOOD

Company presentation

Key contacts:

Tomasz Rolling

Automotive Manager

Mobile: +48 502 671 976

tomaszrolling@vmapolska.pl

Marcin Auguścik

Controls Manager

Mobile: +48 516 128 089

marcinauguscik@vmapolska.pl





vma

SMART TECHNOLOGY
FOR GOOD

**Scan the QR code
to download this
presentation**

